

# ANALYSIS OF AUTOOSCILLATION MICROMECHANICAL GYROSCOPE CHARACTERISTICS

*Alexey Tirtichny*

Saint-Petersburg State University of Aerospace Instrumentation,  
Saint-Petersburg, Russia  
[alekseyguap@mail.ru](mailto:alekseyguap@mail.ru)

## Abstract

A kinematic scheme and principle of an autooscillation micromechanical gyroscope (AMMG) operation are described in this paper. An analytical solution of dynamic equations is gotten using method of harmonic linearization. Also there is a modeling of AMMG in programming software Simulink in this paper. An analysis of an interconnection of AMMG parameters and its characteristics is carried out.

A frequency method of getting of periodic solution parameters is represented. A comparison of different methods is carried out.

Index Terms: micromechanics, angular rate, sensor, gyroscope, autooscillations, construction, dynamics, analytical solution, harmonic linearization method, analysis of characteristics.

## I. INTRODUCTION

Inertial micromechanical sensors are very perspective. They will be much more widely used in different regions of our life in the future [1]. One of the most important tasks for instrumentation engineers today is a development of highly sensitive inertial micromechanical devices with a wide measurement range [2].

AMMG can be used for inertial navigation purposes as a part of a navigation system or stand alone and be used in other applications where rotation rate needs to be measured; examples of these being automotive applications such as traction control systems, ride stabilization and roll-over detection; some consumer electronic applications such as stabilization of pictures in digital video camera and inertial mouse in computers; robotics applications; and, platform stabilization.

## II. PROBLEM AREA

Using of autooscillating low-frequency regimes in the below resonance region allows to solve the problem of increasing sensitivity in small

value and size sensors [2]. As a rule, this reduction leads to the decrease of a measurement range and lowers the accuracy. Reasoning from the theory of information, the self-oscillation regimes that allow passing to FM or TM are of higher potential characteristics than the present-day micromechanical devices based on AM [3].

As it was shown earlier [3], application of autooscillating mechanical systems in various measuring devices will allow many improvements of their characteristics. So it is necessary to carry out analysis of such devices characteristics.

## III. CONSTRUCTION AND PRINCIPLE OF OPERATION

The kinematic scheme of AMMG is presented in fig. 1. A sensor is carried out with silicon technology with the application of electromagnetic and optoelectronic elements. It is a LL-type gyroscope.

Two inertial masses (IM) are monocrystalline silicon plates with rectangular optical gaps. These plates are fixed onto the elastic suspension elements between the magnets. IM can make linear moving on two orthogonally related coordinate axes: longitudinal axis (excitative axis) and lateral axis (output axis). Conducting paths are dusted on the surface of each IM. Light sources (LS) and photodetectors (PD) are fixed along excitative axis and output axis of each IM.

It is established in the paper [2], that application of a magnetoelectric principle of transformation in the micromechanical drivers allows it to increase its power characteristics approximately by 4000 times in comparison with power characteristics of electrostatic drivers. Therefore, production of such drivers gives the chance (with some complication of the technology) to expand a measurement range and to minimize errors of sensors, and also to realize autooscillation regime.

The conducting paths are parallel to the lateral axis. The length of these paths is  $l$ . The induction of magnetic field of magnets is  $B$ .

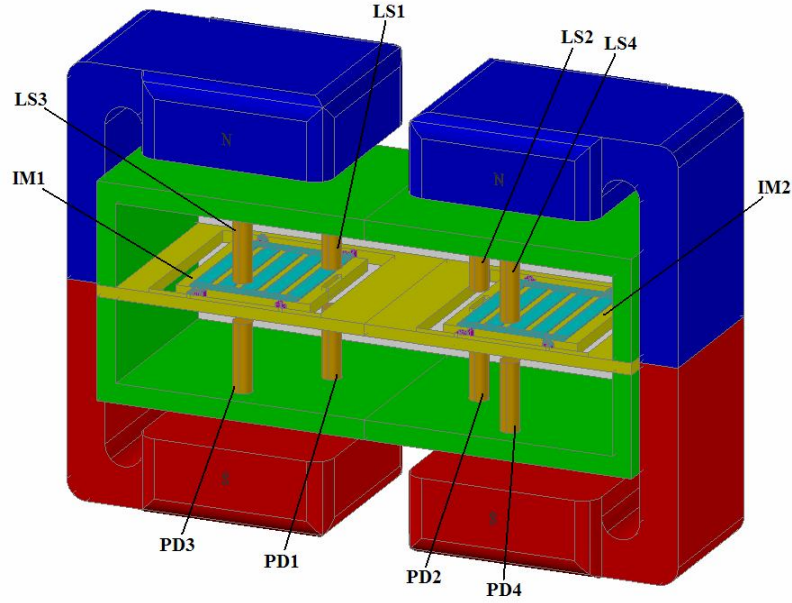

Fig. 1. Kinematic scheme of AMMG

If electric current are created in the  $k$  conducting paths then the magnetic field is created. Then the operating on IM force  $\overline{F}_A$  moves it alongside the longitudinal axis. This force is equal to

$$\overline{F}_A = k \cdot l \cdot \overline{l} \times \overline{B}. \quad (1)$$

This force causes moving of IM along excitative axis. In that moment when the IM blocks an optical channel between a light source and a photodetector. The signal from a photodetector leads to change of a direction of a current and the direction of force of Ampere will change on the opposite. Thus, there will be autooscillations by IM along longitudinal axis. First and second IM oscillate in antiphase.

If micromechanical ARS rotates with angular rate  $\overline{\Omega}$  round the sensitivity axis then it leads to occurrence of Coriolis force  $\overline{F}_K$ . Mass of IM is  $m$ , the speed of IM along the longitudinal axis is  $\overline{v}$ . This force is equal to

$$\overline{F}_K = -2 \cdot m \cdot \overline{\Omega} \times \overline{v}. \quad (2)$$

Owing to action of force  $\overline{F}_K$  the IM makes secondary autooscillations along the lateral axis, thus the light stream of the second PS is modulated by the edge of the IM. An output signal of these PS contains information about measured angular speed.

#### IV. DYNAMICS OF AMMG IM

Dynamics of AMMG was described in [4]. Here is set of IM movement equations:

$$\begin{aligned} m\ddot{x} + \mu_x \dot{x} + \left[ c_x - m(\omega_z^2 + \omega_y^2) \right] x - 2m\omega_z \dot{y} - \\ - m\dot{\omega}_z y + m\omega_x \omega_y y = \end{aligned}$$

$$-m\dot{V}_x + m(V_y \omega_z - V_z \omega_y) + F, \quad (3)$$

$$\begin{aligned} m\ddot{y} + \mu_y \dot{y} + \left[ c_y - m(\omega_z^2 + \omega_x^2) \right] y + 2m\omega_z \dot{x} + \\ + m\dot{\omega}_z x + m\omega_x \omega_y x = -m\dot{V}_y + m(V_z \omega_x - V_x \omega_z) \end{aligned} \quad (4)$$

The equations (3) and (4) define conditions of the dynamic balance of the forces operating along longitudinal and lateral axes. Because of the sensor is intended for measurement of angular rate  $\omega_z$ , we consider a special case of the equations (3) and (4) when  $\omega_x = \omega_y = 0$ ,  $V_x = V_y = V_z = 0$ , and angular rate  $\omega_z$  is constant. Then

$$m\ddot{x} + \mu_x \dot{x} + (c_x - m\omega_z^2)x - 2m\omega_z \dot{y} = F, \quad (5)$$

$$m\ddot{y} + \mu_y \dot{y} + (c_y - m\omega_z^2)y - 2m\omega_z \dot{x} = 0 \quad (6)$$

This simplified system of equations describes IM dynamic. It is nonlinear because force  $F$  is some nonlinear function of  $x$ .

The simplified model of AMMG is based on the set of equations (5) and (6). Dynamics of the system and its transients could be examined using this model and programming software Simulink.

The size of IM is  $5 \times 5$  mm. There are 150 aluminic conducting paths, their width is  $23,4 \mu\text{m}$ , clearance between them is  $10 \mu\text{m}$ . The characteristics of such force transducers are more detailed in [2].

The simplified modelling's schemes of driving channel and output channel are represented in fig. 2 and fig. 3. The scheme of AMMG is represented in fig.4. Next abbreviations are used:  $\Omega$  – a measurable angular rate;  $v_{x1}$  и  $v_{x2}$  – linear velocities of IM1 and IM2 along axis  $x$ ;  $v_{y1}$  и  $v_{y2}$  – linear velocities of IM1 and IM2 along axis  $y$ ;  $F_D$  – a driving force; FT – a force transducer; OT – an optical transducer.

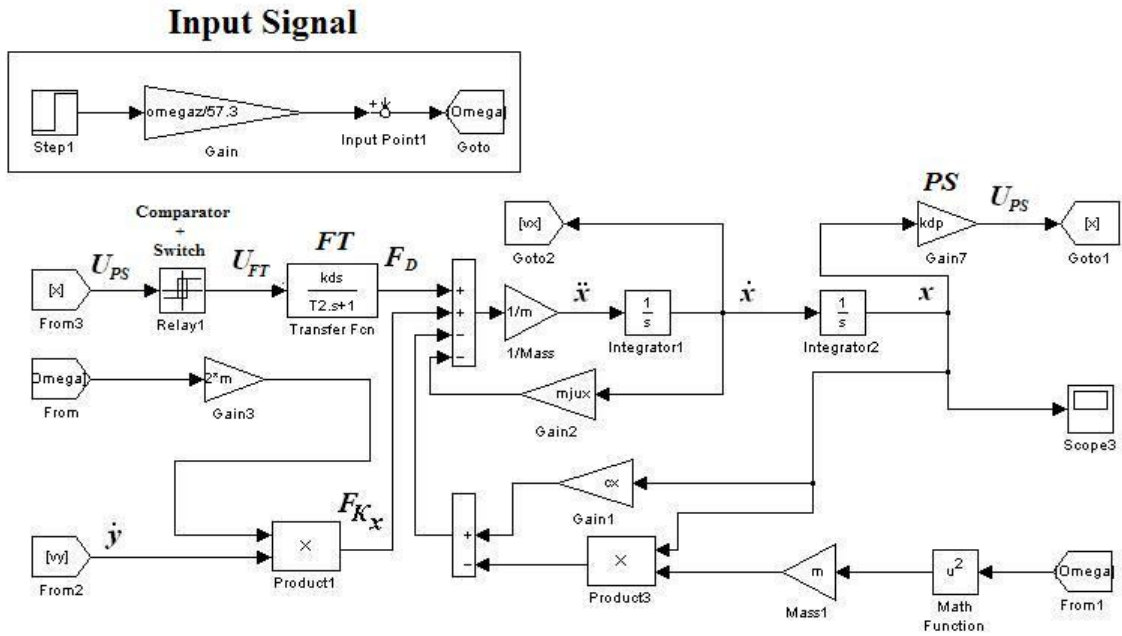

Fig. 2. Driving channel of AMMG

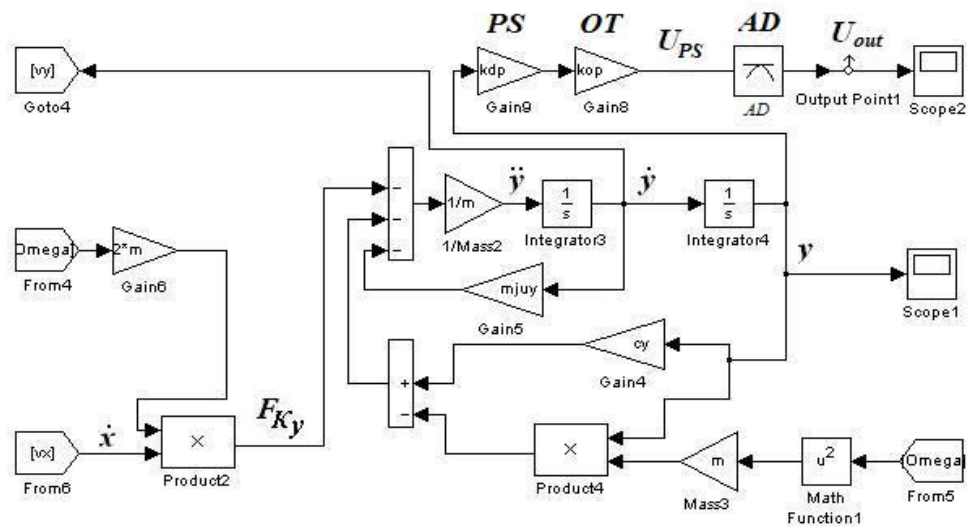

Fig.3. Output channel of AMMG

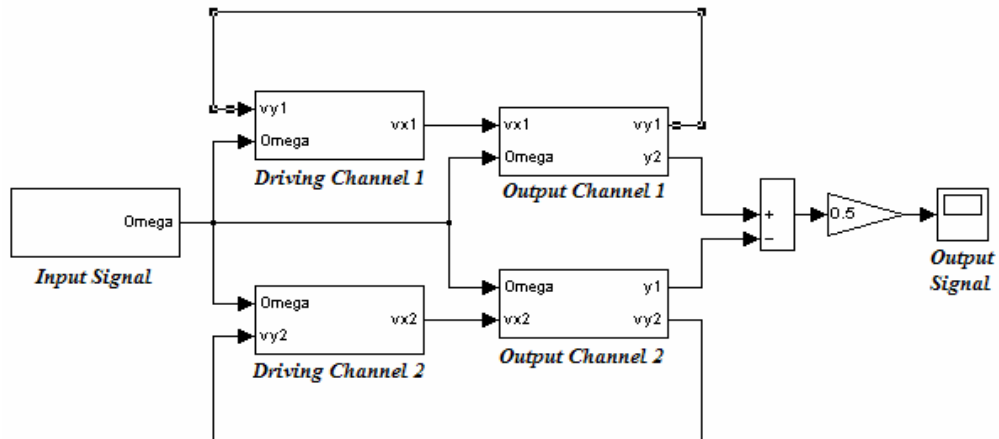

Fig. 4. Scheme of AMMG

Using of two IM in scheme allows to avoid quite a number of different errors owing to finding of two antiphased signals' difference.

Consequently, as a result of modeling the amplitude and the frequency of output channel are equal to  $A = 260 \mu\text{m}$ ,  $\Omega = 706 \text{ Hz}$ .

Using method of harmonic linearization [5] analytical solution of system of equations (5) and (6) can be gotten. The equation (5) could be translated into a state space

$$Q(j\Omega) + R(j\Omega)(q + jq') = 0 \quad (7)$$

$$Q(j\Omega) = -m\Omega^2 + \mu_x \Omega j + c_x - m\omega_z^2, \quad R(j\Omega) = 1 \quad (8)$$

If real and imaginary parts are separated then the set of equations is gotten

$$-m\Omega^2 + c_x - m\omega_z^2 + \frac{4F_m}{\pi A} \sqrt{1 - \frac{x_m}{A^2}} = 0 \quad (9)$$

$$\mu_x \Omega - \frac{4F_m x_m}{\pi A^2} = 0 \quad (10)$$

If we solve this set then we get

$$A = 260 \mu\text{m}, \quad \Omega = \frac{4F_m x_m}{\pi \mu_x A^2} = 671 \text{ Hz}.$$

These values are close to the results of modelling ( $A = 260 \mu\text{m}$ ,  $\Omega = 706 \text{ Hz}$ ). Therefore the analytical method that was described can be used for analysis of AMMG characteristics.

## V. METHODS OF ANALYSIS

The influence of equation (5) parameters under the characteristics of AMMG can be researched using this analytical solution. The longitudinal linear speed of IM should be maximal to ensure optimal characteristics of the sensor. Then values of Coriolis force and lateral amplitude be maximal. But longitudinal and lateral oscillation frequencies of IM are the same. So the initial longitudinal amplitude should be bigger to make the metrological characteristics of AMMG better.

Let the parameters be the same as in [6] and as in modelling. The influence of these parameters can be researched. Each parameter can be modified, other parameters should be invariable.

The influence of excitation force  $F_a$  under parameters of the autooscillating system (frequency  $\Omega$  (*omega*) and amplitude  $A$  (*Abol*)) are represented in fig. 5. Values of excitation force  $F_a$  are represented in table 1.

Table 1.

Influence of excitation force  $F_a$  under parameters of the autooscillating system

Excitation force $F_a$ , $\mu\text{N}$	Frequency $\Omega$ , Hz	Amplitude $A$ , $\mu\text{m}$
36	1700	58
72	1000	100
168	790	180
300	687	264
600	600	400

Thereby the value of excitation force  $F_a$  should be greater to make the metrological characteristics of AMMG better.

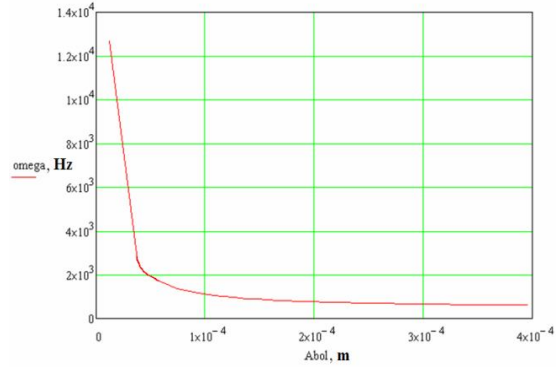

Fig. 5. Influence of excitation force  $F_a$  under parameters of the autooscillating system

The influence of suspension rigidity  $c_x$  under parameters of the autooscillating system are represented in fig. 6. Values of suspension rigidity  $c_x$  are represented in table 2.

Table 2.

Influence of suspension rigidity  $c_x$  under parameters of the autooscillating system

Suspension rigidity $c_x$ , N/m	Frequency $\Omega$ , Hz	Amplitude $A$ , $\mu\text{m}$
1	250	440
5	687	264
10	1000	210
15	1400	190
26	2000	160

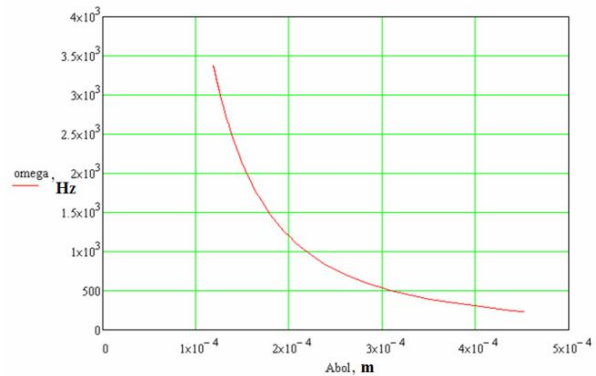

Fig. 6. Influence of suspension rigidity  $c_x$  under parameters of the autooscillating system

Thus the value of suspension rigidity  $c_x$  should be less to make the metrological characteristics of AMMG better.

The influence of damping  $\mu_x$  under parameters of the autooscillating system are represented in fig. 7. Values of damping  $\mu_x$  are represented in table 3.

Table 3.

Influence of damping  $\mu_x$  under parameters of the autooscillating system

Damping $\mu_x$ , $\mu\text{N}\cdot\text{s}/\text{m}$	Frequency $\Omega$ , Hz	Amplitude $A$ , $\mu\text{m}$
1	500	8800
100	550	830
500	640	350
1000	720	230
5000	1400	70

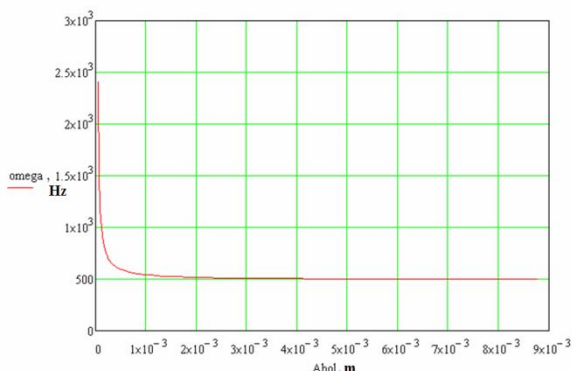

Fig. 7. Influence of damping  $\mu_x$  under parameters of the autooscillating system

So the value of damping  $\mu_x$  should be less to make the metrological characteristics of AMMG better.

The influence of distance between position sensors  $x_m$  under parameters of the autooscillating system are represented in fig. 8. Values of the distance between position sensors  $x_m$  are represented in table 4.

Table 4. Influence of damping  $\mu_x$  under parameters of the autooscillating system

Distance between position sensors $x_m$ , $\mu\text{m}$	Frequency $\Omega$ , Hz	Amplitude $A$ , $\mu\text{m}$
25	990	110
100	687	264
500	570	650
1000	550	940

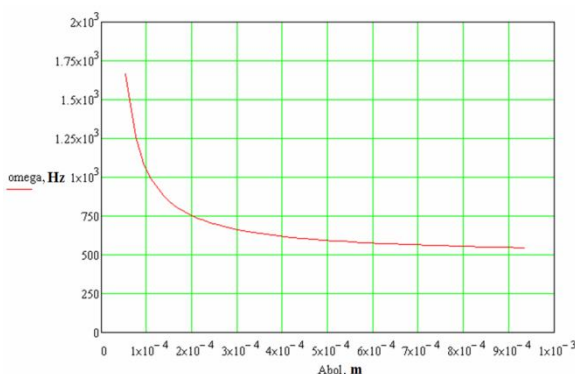

Fig. 8. Influence of distance between position sensors  $x_m$  under parameters of the autooscillating system

Thereby the value of distance between position sensors  $x_m$  should be greater to make the metrological characteristics of AMMG better.

The influence of IM  $m$  under parameters of the autooscillating system are represented in fig. 9. Values of IM  $m$  are represented in table 5.

Table 5. Influence of IM  $m$  under parameters of the autooscillating system

IM $m$ , mg	Frequency $\Omega$ , Hz	Amplitude $A$ , $\mu\text{m}$
5	1200	200
10	710	250
12	687	264
20	510	310

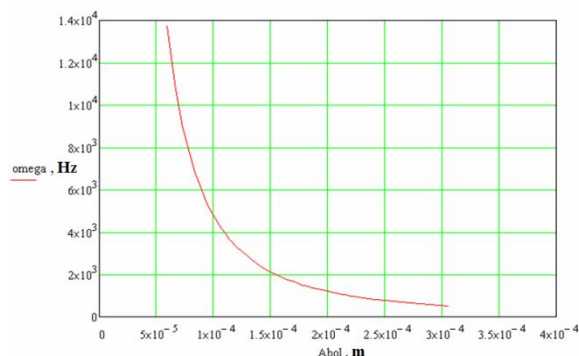

Fig. 9. Influence of IM  $m$  under parameters of the autooscillating system

Thus the value of IM  $m$  should be greater to make the metrological characteristics of AMMG better.

But if nonlinear function is rather complicated then getting of analytical solution, that represented in paragraph IV, could be either very difficult or impossible, because the equations (9) and (10) might be transcendental relatively to unknown variables.

Sometimes it's more convenient to use a frequency method of getting of periodic solution parameters on a number of occasions, especially at the stage of preliminary analysis and synthesis of a system. This method is based on the research of open-loop system's gain-phase characteristic (GPC)

$$W(i\Omega) = W_l(i\Omega)W_n(A). \quad (11)$$

It's can be gotten using equations (8) and (9).

If there are two imaginary roots in a characteristic equation of a closed loop system then this system should pass through the point (-1, 0) according to Nyquist criterion. Thus the periodic solution is determined as

$$W_l(i\Omega) = -\frac{1}{W_n(A)}. \quad (12)$$

GPC of the linear part is equal to

$$W_l(i\Omega) = \frac{k_{ps}}{(T_2 i\Omega + 1)(-m\Omega^2 + \mu_x i\Omega + c_x)}, \quad (13)$$

$k_{ps}$  – a conversion factor of the position sensor.

An amplitude characteristic (AC) of the nonlinear part is equal to

$$W_n(A) = q + jq'. \quad (14)$$

GPC of the linear part ( $W_{lin}(\omega)$ ) and the right side of equation (12) ( $W_{nel}(Amp)$ ) are shown in a complex plane in fig. 10.

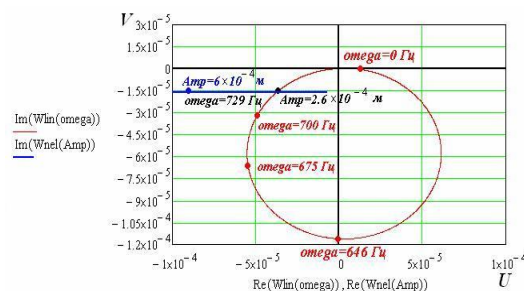

Fig. 10. GPC of the linear part ( $W_{lin}(\omega)$ ) and the right side of equation (12) ( $W_{nel}(Amp)$ )

A cross point of these graphs is a solution of the equation (12). This solution are a value of the cyclic frequency (*omega*) that is found in the graph  $W_i(i\Omega)$  and a value of amplitude  $A$  (*Amp*) that is found in the graph  $-1/W_n(A)$ . These values are equal to  $\Omega = 729 \text{ Hz}$ ,  $A = 2.6 \cdot 10^{-4} \text{ m}$ .

These values are close to the results of modelling ( $\Omega = 706 \text{ Hz}$ ,  $A = 260 \text{ }\mu\text{m}$ ). Therefore the frequency method that was described can be used for analysis of AMMG characteristics too.

## VI. CONCLUSIONS

Dynamics of AMMG IM is described in this paper. The model of AMMG in programming software Simulink is represented. Two methods of its characteristics' analysis are suggested. The researches of AMMG show that its development allows to achieve many improvements of micromechanical gyroscopes' metrological characteristics.

The final purpose is the creation of micromechanical gyroscopes with a wider measurement range and bigger accuracy in comparison with the micromechanical devices those

existing today. Furthermore the research of AMMG dynamic behavior is planed.

## REFERENCES

- [1] *G.T. Schmidt*, "INS/GPS Technology Trends //Advances in navigation sensors and integration technology". NATO RTO Lecture series 232, 2004.
- [2] *Tirtichny A.* The comparative analysis of characteristics of compensating converters of micromechanical inertial sensors // Information and communication technologies: problems, perspectives. 2008. P. 76-80.
- [3] *Попов Е.П.* Прикладная теория процессов управления в нелинейных системах. М.: Наука, 1973. 583 с.
- [4] *Тыртычный А. А.* Микромеханический датчик угловой скорости, работающий в режиме автоколебаний // Научная сессия ГУАП: Сб. докл.: В 3 ч. Ч. 1. Технические науки/ СПбГУАП. СПб., 2009. С. 60-63.
- [5] *Пальтов И. П., Попов Е. П.* Приближённые методы исследования нелинейных автоматических систем. – М: Физматгиз, 1960. 792 с.
- [6] *Тыртычный А., Скалон А.* Анализ характеристик компенсирующих преобразователей микромеханических инерциальных датчиков// Датчики и системы. 2009. № 2. С. 21–23.

*I thank professor Anatoly Ivanovich Scalon for helping me with this paper.*